

23V, 3A, 340KHz Synchronous Step-Down DC/DC Converter

Description

The FR9888 is a synchronous step-down DC/DC converter that provides wide 4.5V to 23V input voltage range and 3A continuous load current capability.

Fault protection includes cycle-by-cycle current limit, input UVLO, output over voltage protection and thermal shutdown. Besides, adjustable soft-start function prevents inrush current at turn-on. This device uses current mode control scheme that provides fast transient response. In shutdown mode, the supply current is about 1uA.

The FR9888 is available in an 8-pin SOIC package, provides a very compact system solution and good thermal conductance.

Features

- Wide Input Voltage from 4.5V to 23V
- 3A Output Current
- Adjustable Output Voltage from 0.925V to 14V
- Low Rds(on) integrated Power MOSFET
- High Efficiency Up to 93%
- Fixed 340KHz Switching Frequency
- Current Mode Operation
- Adjustable Soft-Start
- Cycle-by-Cycle current limit
- Input Under Voltage Lockout
- Over-Temperature Protection With Auto Recovery
- 1uA Shutdown Current
- Internal Compensation Function
- SOP-8 and Thermal Enhanced SOP-8P Packages
- RoHS Compliant

Applications

- Set-Top-Box
- DVD, LCD Displays
- OLPC, Netbook
- Datacom, XDSL

Pin Assignments

SP Package (SOP- 8 Expose pad)

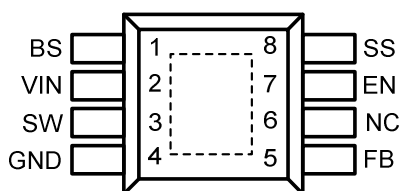
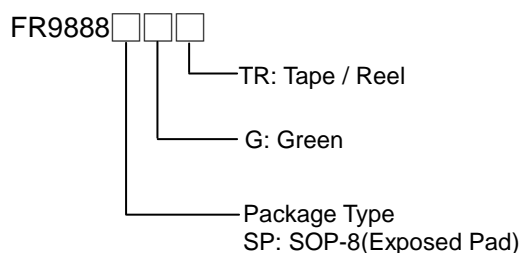

Figure 1. Pin Assignment of FR9888

Ordering Information



Typical Application Circuit

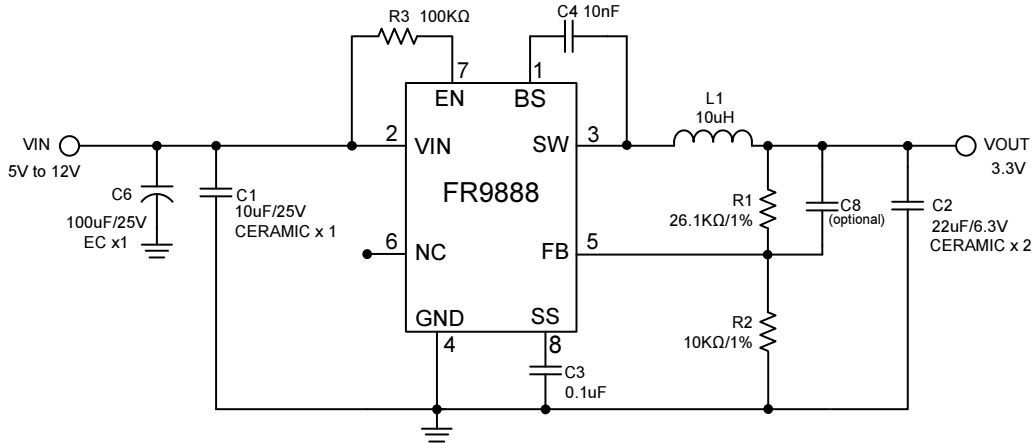

Figure 2. Output 3.3V Application Circuit

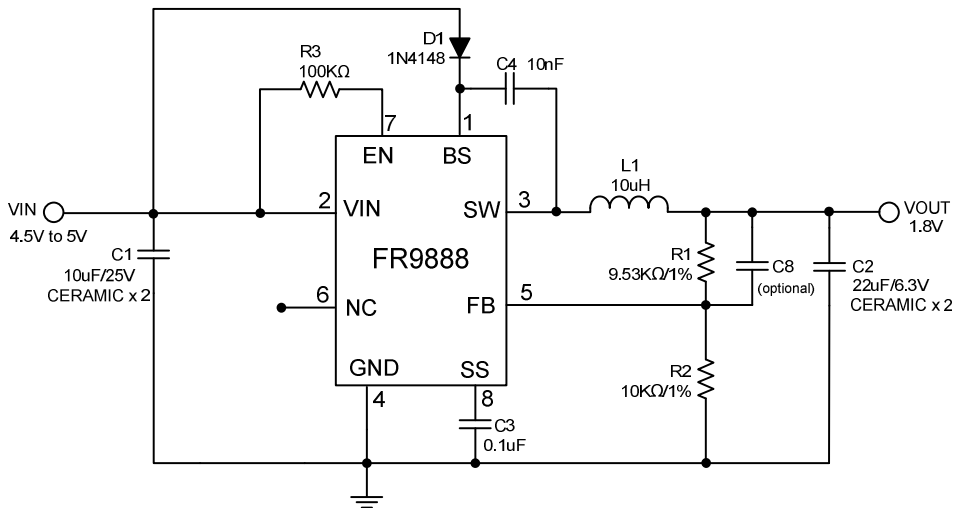

Figure 3. Low Input Voltage Application Circuit

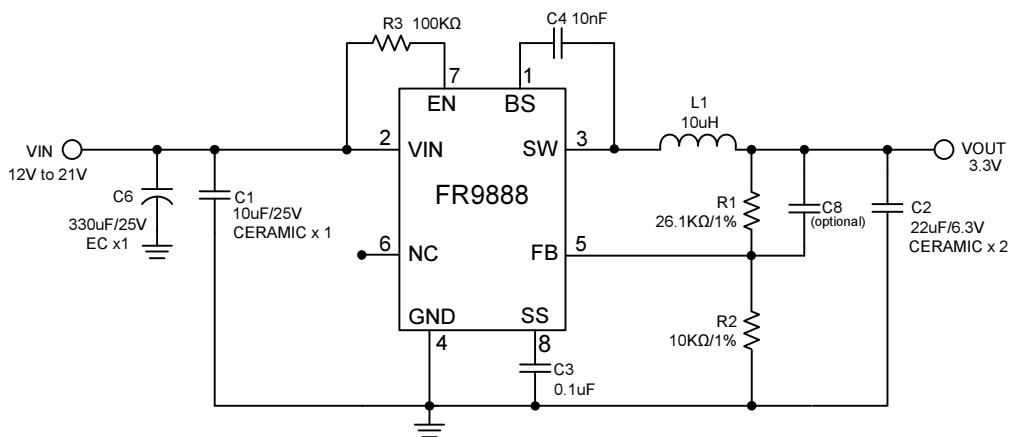

Figure 4. High Input Voltage Application Circuit

Functional Pin Description

Pin Name	Pin Function
BS	High Side Gate Drive Boost Input. A 10nF or greater capacitor must be connected from this pin to SW. It can boost the gate drive to fully turn on the internal high side NMOS.
VIN	Power Supply Input Pin. Drive 4.5V to 23V voltage to this pin to power on this chip.
SW	Power Switching Output. It is the output pin that internal high side NMOS switching to supply power.
GND	Ground Pin. Connecting this pin to exposed pad.
FB	Voltage Feedback Input Pin. Connecting FB and VOUT with a resistive voltage divider. This IC senses feedback voltage via FB and regulate it at 0.925V.
NC	No connection. Keeping this pin floating.
EN	Enable Input Pin. This pin provides a digital control to turn the converter on or off. Connect to VIN with a 100KΩ resistor for self-startup.
SS	Soft-Start Input Pin. This pin controls the soft-start period. Connect a capacitor from SS to GND to set the soft start period.

Block Diagram

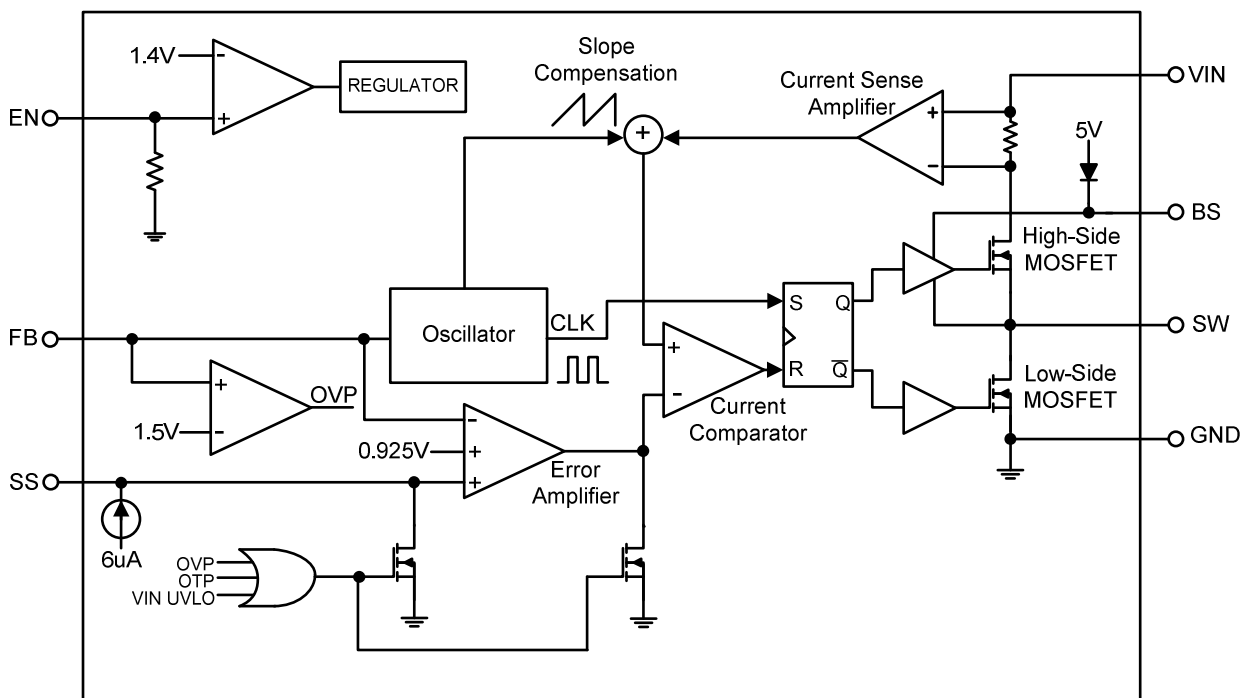

Figure 5. Block Diagram of FR9888

Absolute Maximum Ratings

- Supply Voltage V_{IN} ----- - 0.3V to + 26V
- SW Voltage V_{SW} ----- -1V to $V_{IN} + 0.3V$
- Boost Trap Voltage V_{BS} ----- $V_{SW} - 0.3V$ to $V_{SW} + 6V$
- All Other Pins Voltage ----- - 0.3V to + 6V
- Maximum Junction Temperature (T_J)----- + 150°C
- Storage Temperature (T_S)----- - 65°C to + 150°C
- Lead Temperature (Soldering, 10sec.) ----- +260°C
- Power Dissipation @ $T_A=25^\circ C$, (P_D)
 - SOP-8 (Exposed Pad)----- 1.25W
- Package Thermal Resistance, (θ_{JA}):
 - SOP-8 Exposed Pad----- 50°C/W
- ESD Susceptibility
 - HBM(Human Body Mode)----- 2KV

Note1 : Stresses beyond those listed under "Absolute Maximum Ratings" may cause permanent damage to the device.

Recommended Operating Conditions

- Supply Voltage (V_{IN})----- 4.5V ~ 23V
- Output Voltage (V_{OUT}) ----- 0.925V ~ 16V
- Operation Temperature Range----- - 40°C to + 85°C

Electrical Characteristics

($V_{IN}=12V$, $T_A=25^{\circ}C$, unless otherwise specified.)

Parameter	Conditions	Min	Typ	Max	Unit
V_{IN} Input Supply Voltage (Note2)		4.5		23	V
V_{IN} Supply Current	$V_{EN} = 1.8V$		1.1		mA
V_{IN} Shutdown Supply Current	$V_{EN} = 0V$		1		μA
Feedback Voltage	$4.5V \leq V_{IN} \leq 18V$	0.9	0.925	0.95	V
Feedback OVP Threshold Voltage			1.5		V
High-Side MOSFET $R_{DS(ON)}$ (Note3)			130		m Ω
Low-Side MOSFET $R_{DS(ON)}$ (Note3)			100		m Ω
High-Side MOSFET Leakage Current	$V_{EN} = 0V$, $V_{SW} = 0V$			10	μA
High-Side MOSFET Current Limit (Note3)	Minimum Duty	4	5		A
Low-Side MOSFET Current Limit (Note3)			3		A
Error Amplifier Voltage Gain (Note3)			400		V/V
Oscillation frequency		280	340	380	KHz
Short Circuit Oscillation Frequency	$V_{FB} = 0V$		110		KHz
Maximum Duty Cycle	$V_{FB} = 0.8V$		90		%
Minimum On Time (Note3)			220		ns
Input UVLO Threshold	V_{IN} Rising		4.4		V
Under Voltage Lockout Threshold Hysteresis			300		mV
Soft-Start Current			6		μA
Soft-Start Period	$C_{SS} = 0.1\mu F$		15		ms
EN Input Low Voltage				0.4	V
EN Input High Voltage		2			V
EN Input Current	$V_{EN} = 2V$		2		μA
Thermal Shutdown Threshold (Note3)			160		$^{\circ}C$

Note2 : When $V_{IN} = 4.5V$, $V_{OUT} = 3.3V$, maximum load current is about 1A.

Note3 : Not production tested.

Function Description

The FR9888 is a constant frequency current mode step-down synchronous DC/DC converter. It regulates input voltage from 4.5V to 18V, down to an output voltage as low as 0.925V, and can provide 3A of continuous load current.

Control Loop

During normal operation, the output voltage is sensed at FB pin through a resistive voltage divider and amplified through the error amplifier. The voltage of error amplifier output is compared to the switch current to controls the RS latch. At each cycle, the high side NMOS would be turned on when the oscillator sets the RS latch and would be turned off when current comparator resets the RS latch. When the load current increases, the FB pin voltage drops below 0.925V, it causes the error amplifier output voltage increase until average inductor current arrive at new load current.

Enable

The FR9888 EN pin provides digital control to turn on/turn off the regulator. When the voltage of EN exceeds the threshold voltage, the regulator starts the soft start function. If the EN pin voltage is below than the threshold voltage, only the bandgap voltage is alive. If the EN pin voltage is below than the shutdown threshold voltage, the regulator will be disable and into the shutdown mode.

Maximum Load Current

The maximum load current decreases at lower input voltage because of large IR drop on the high side switch and low side switch. The slope compensation signal reduces the peak inductor current as a function of the duty cycle to prevent sub-harmonic oscillations at duty cycles greater than 50%.

Output Over Voltage Protection

When the FB pin voltage exceeds 1.5V, the output over voltage protection function will discharge the error amplifier output and the SS pin to GND, turning the high side MOSFET off.

Input Under Voltage Lockout

When the FR9888 power on, the internal circuits are held inactive until V_{IN} exceeds the input UVLO threshold voltage. And the regulator will be disabled when V_{IN} below the input UVLO threshold voltage. The hysteric of the UVLO comparator is 300 mV.

Short Circuit Protection

The FR9888 provides short circuit protection function to prevent the device damage from short condition. When the output short to ground, the oscillator frequency is reduced to prevent the inductor current increasing beyond the current limit. In the meantime, the current limit is also reduced to lower the short current. Once the short condition is removed, the frequency and current limit will return to normal.

Over Temperature Protection

The FR9888 incorporates an over temperature protection circuit to protect itself from overheating. When the junction temperature exceeds the thermal shutdown threshold temperature, the regulator will be shutdown, and re-enables when the IC junction temperature drops by 30°C (typ).

Internal Compensation Function

The stability of the feedback circuit is controlled through internal compensation circuits. This internal compensation function is optimized for most applications and this function can reduce external R, C components.

Application Information

Output Voltage Setting

The output voltage V_{OUT} is set using a resistive divider from the output to FB. The FB pin regulated voltage is 0.925V. Thus the output voltage is:

$$V_{OUT} = 0.925 \times \left(1 + \frac{R1}{R2} \right) \text{ V}$$

R2 recommended value is 10k Ω , so R1 is determined by:

$$R1 = 10.81 \times (V_{OUT} - 0.925) \text{ k}\Omega$$

Table 1 lists recommended values of R1 and R2 for most used output voltage.

Table 1 Recommended Resistance Values

V_{OUT}	R1	R2
5V	44.2 k Ω	10 k Ω
3.3V	26.1 k Ω	10 k Ω
2.5V	16.9 k Ω	10 k Ω
1.8V	9.53 k Ω	10 k Ω
1.2 V	3 k Ω	10 k Ω

Place resistors R1 and R2 close to FB pin to prevent stray pickup.

Input Capacitor Selection

The use of the input capacitor is controlling the input voltage ripple and the MOSFETS switching spike voltage. Because the input current to the step-down converter is discontinuous, the input capacitor is required to supply the current to the converter to keep the DC input voltage. The capacitor voltage rating should be 1.25 times to 1.5 times greater than the maximum input voltage. The input capacitor ripple current RMS value is calculated as:

$$I_{IN(RMS)} = I_{OUT} \times \sqrt{D \times (1-D)}$$

Where D is the duty cycle of the power MOSFET.

A low ESR capacitor is required to keep the noise minimum. Ceramic capacitors are better, but tantalum or low ESR electrolytic capacitors may also suffice. When using tantalum or electrolytic capacitors, a 10 μ F ceramic capacitor should be placed as close to the IC as possible.

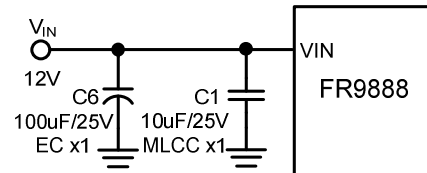

It is recommended that the input EC capacitor be added for applications if the FR9888 will suffer high spike input voltage (ex. hot plug test). It can eliminate the spike voltage induced the IC damage from high input voltage stress (see Note1).

Table 2 lists recommended values of C1 and C6 for most used input voltage.

Table 2 Recommended Capacitor Values

V_{IN}	C1	C6
5V	10 μ F X2	---
12V	10 μ F X1	100 μ F X1
15V	10 μ F X1	330 μ F X1
18V	10 μ F X1	330 μ F X1

Output Capacitor Selection

The output capacitor is used to keep the DC output voltage and supply the load transient current. Low ESR capacitors are preferred. Ceramic, tantalum or low ESR electrolytic capacitors can be used, depends on the output ripple requirement. Add a 100 μ F or 470 μ F Low ESR electrolytic capacitor when operated in high input voltage range. It can improve the device's stability. The output ripple voltage ΔV_{OUT} is described as:

$$\Delta I = \frac{V_{OUT}}{F_{OSC} \times L} \times \left(1 - \frac{V_{OUT}}{V_{IN}} \right)$$

$$\Delta V_{OUT} = \Delta I \times \left(R_{ESR} + \frac{1}{8 \times F_{OSC} \times C_{OUT}} \right)$$

Where ΔI is the peak-to-peak inductor ripple current, F_{OSC} is the switching frequency, L is the inductance value, V_{IN} is the input voltage, V_{OUT} is the output voltage, R_{ESR} is the equivalent series resistance value of the output capacitor, and the C_{OUT} is the output capacitor. When using the ceramic capacitors, the RESR can be ignored and the output ripple voltage ΔV_{OUT} is shown as:

$$\Delta V_{OUT} = \frac{\Delta I}{8 \times F_{OSC} \times C_{OUT}}$$

Application Information (Continued)

When using tantalum or electrolytic capacitors, typically 90% of the output voltage ripple is contributed by the ESR of output capacitors. the output ripple voltage ΔV_{OUT} can be estimated as:

$$\Delta V_{OUT} = \Delta I \times R_{ESR}$$

Output Inductor Selection

The output inductor is used for store energy and filter output ripple current. But the trade-off condition often happens between maximum energy storage and the physical size of the inductor. The first consideration for selecting the output inductor is to make sure that the inductance is large enough to keep the converter in the continuous current mode. That will lower ripple current and results in lower output ripple voltage. A good rule for determining the inductance is set the peak-to-peak inductor ripple current ΔI almost equal to 30% of the maximum load current. Then the minimum inductance can be calculated with the following equation:

$$\Delta I = 0.3 \times I_{OUT(MAX)}$$

$$L \geq (V_{IN} - V_{OUT}) \times \left(\frac{V_{OUT}}{F_{OSC} \times \Delta I \times V_{IN}} \right)$$

Where V_{IN} is the maximum input voltage.

External Boost Diode Selection

For 5V input applications, it is recommended that an external boost diode be added. This helps improve the efficiency. The boost diode can be a low cost one such as 1N4148.

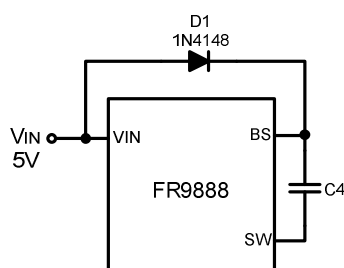

This diode is also recommended for high duty cycle operation (when duty cycle > 65%, $V_{IN} < 15V$).

PCB Layout Recommendation

The device's performance and stability is dramatically affected by PCB layout. It is recommended to follow these general guidelines show below:

1. Place the input capacitors, output capacitors as close to the device as possible. Trace to these capacitors should be as short and wide as possible to minimize parasitic inductance and resistance.
2. Place V_{IN} capacitors close to the V_{IN} pin.
3. Place feedback resistors close to the FB pin.
4. Keep the sensitive signal (FB) away from the switching signal (SW).
5. The exposed pad of the package should be soldered to an equivalent area of metal on the PCB. This area should connect to the GND plane and have multiple via connections to the back of the PCB as well as connections to intermediate PCB layers. The GND plane area connects to the exposed pad should be maximized to improve thermal performance.
6. Multi-layer PCB design is recommended.

Application Information (Continued)

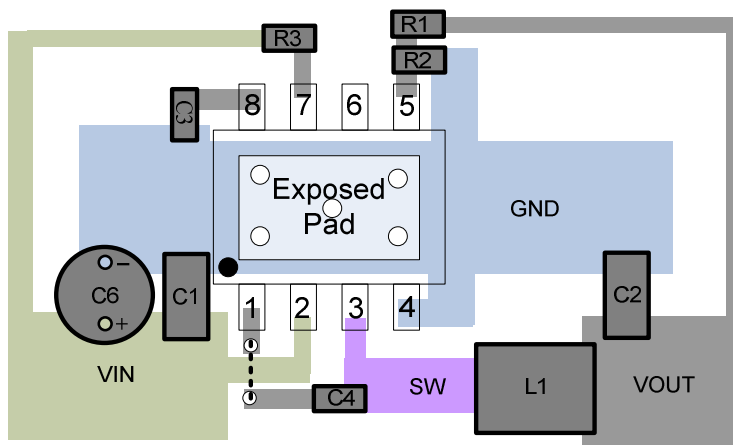
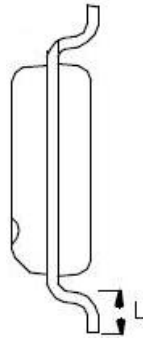
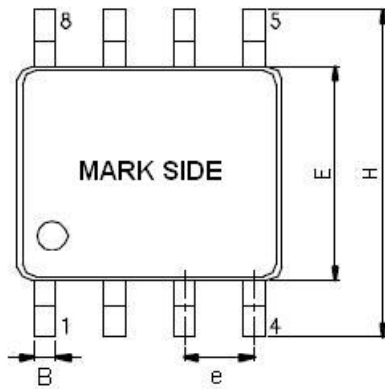

Figure19. FR9888 Recommended Layout Diagram

Outline Information

SOP- 8 Package (Unit: mm)



SYMBOLS UNIT	DIMENSION IN MILLIMETER	
	MIN	MAX
A	1.35	1.75
A1	0.05	0.25
A2	1.30	1.50
B	0.31	0.51
D	4.80	5.00
E	3.80	4.00
e	1.20	1.34
H	5.80	6.20
L	0.40	1.27

Note : Followed From JEDEC MO-012-E

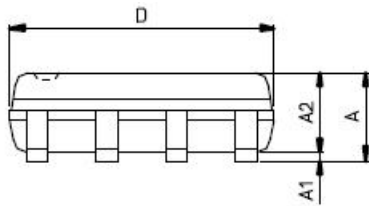

Outline Information (Continued)

SOP- 8 (Exposed Pad) Package (Unit: mm)

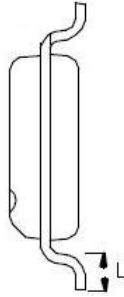
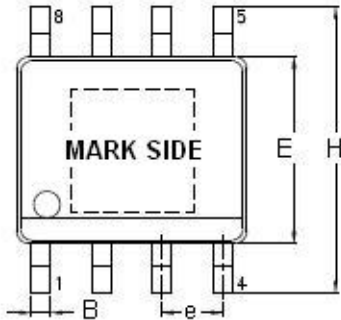

SYMBOLS UNIT	DIMENSION IN MILLIMETER	
	MIN	MAX
A	1.25	1.70
A1	0.00	0.15
A2	1.25	1.55
B	0.31	0.51
D	4.80	5.00
D1	1.82	3.35
E	3.80	4.00
E1	1.82	2.41
e	1.20	1.34
H	5.80	6.20
L	0.40	1.27

Note : Followed From JEDEC MO-012-E.

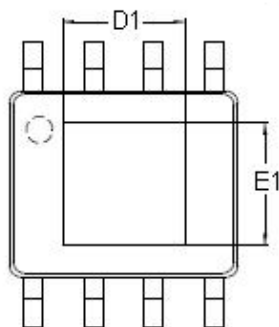
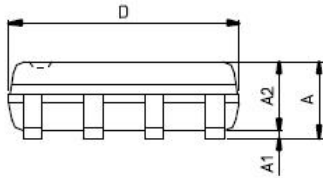

Life Support Policy

Fitipower's products are not authorized for use as critical components in life support devices or other medical systems.